

RoHS Compliant HF

REV.	ECN.NO.	MODIFY.CONTENT
A		NEW
B	N23060601	CHANGE LATCH AND FIXD

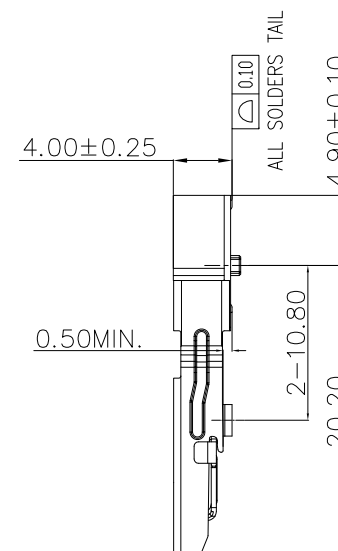

NOTES:
 1.FINISH:
 1.1 CONTACT:50u" MIN NICKEL UNDERPLATED ALL OVER.
 GOLD FALSH PLATING ON SOLDERAIL.
 GOLD PLATING (THICKNESS SEE P/N)NO CONTACT AREA.
 1.2 SOLDER PEG:
 50u"MIN NICKEL UNDERPLATED ALL OVER.
 100u"MIN MATTE TIN PLATING ENTIRE OVER.
 2.DATE CODE:YYWDLX.
 YY:YEAR(20:2020)
 MM:MONTH(01:JANUARY)
 DD:DAY(1~31)
 3.RECOMMENDED STENCIL THICKNESS:0.12mm MIN

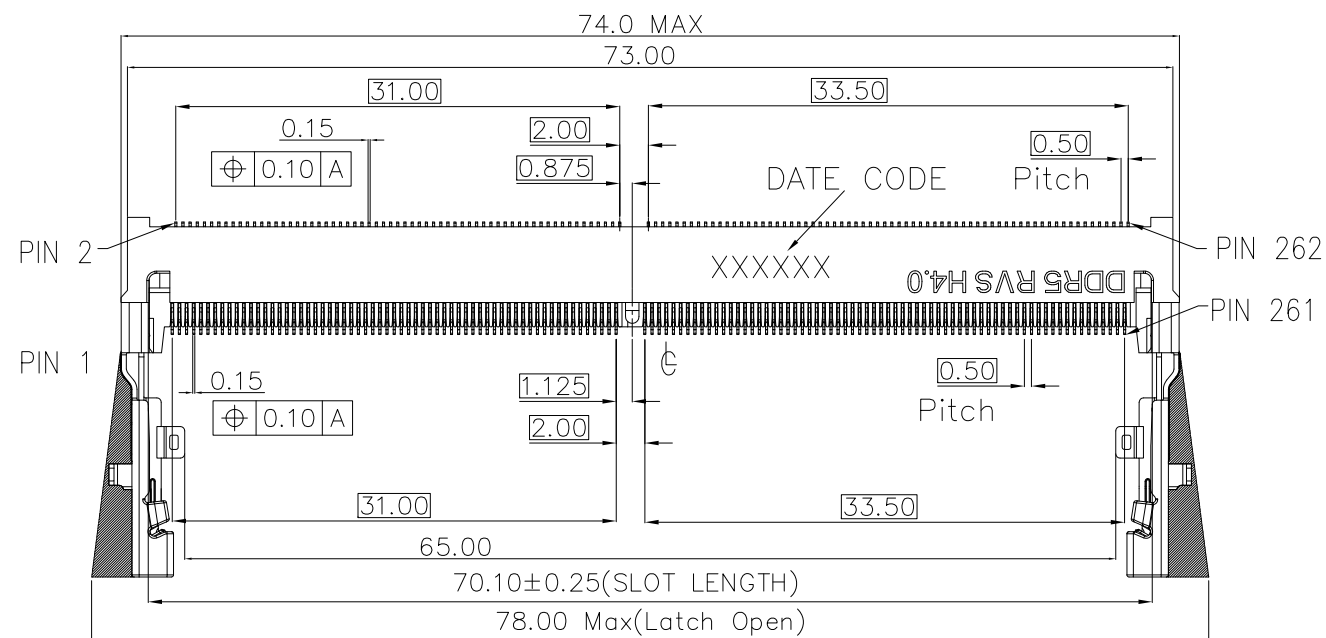
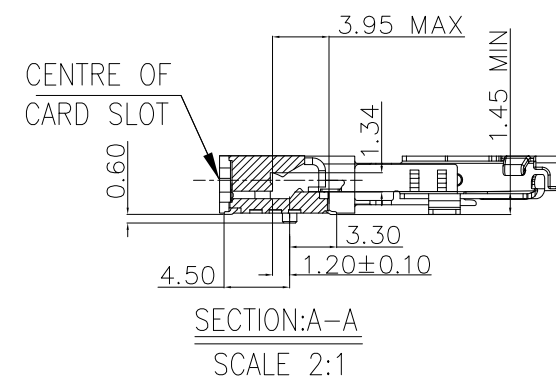
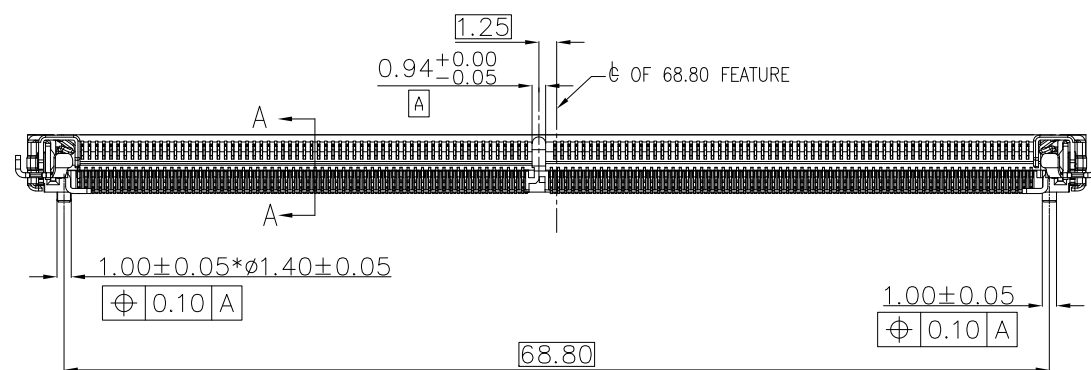

PART.NO.:
 DDR001-S5401-**
 08: 1U"
 09: 3U"
 10: 5U"
 11: 10U"
 12: 15U"
 13: 30U"

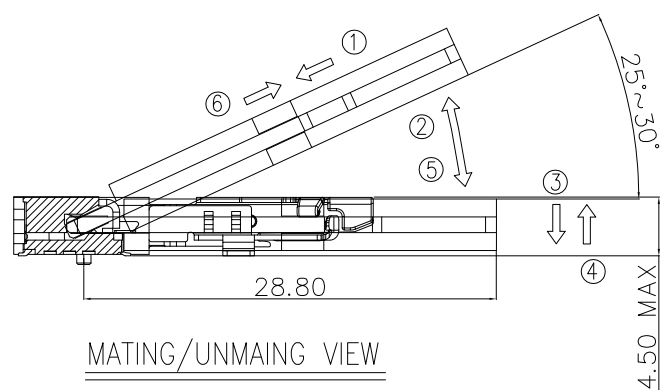

MATING:① INSETING(25)→②ROTATING →③ FIXED
 UNMATING:④ INSETING(25)→⑤ROTATING →⑥WITHDRAWING

G	FIXED-B	1	SUS304 0.35T	Matt Tin plating All Over 120u"Min
F	FIXED-A	1	SUS304 0.35T	
E	LATCH-B	1	SUS304 0.35T	Clear
D	LATCH-A	1	SUS304 0.35T	
C	TERMINAL-B	131	C5210 0.15T	Contact area gold plating Solder TAIL G/F Ni 50u"Min Underplate
B	TERMINAL-A	131	C5210 0.15T	
A	HOUSING	1	LCP,UL94V-0	BLACK.
NO	DESCRIPTION	QTY	MATERIAL	PLATING & COLOR

GENERAL TOLERANCE	TOLERANCE	DWG.NO.	DDR001-S5401-08	PART.NO.	DDR001-S5401-**	DRAWN	DU 2023-06-06	UNIT	mm	SCALE	NO SCALE
x.±0.50	x.°± 5°	REV.	B	TITLE	DDR5 SO DIMM 262Pin(RVS) H4.0	CHECKED		东莞市欧联电子科技有限公司 DONGGUAN OLN ELECTRONICS TECHNOLOGY CO., LTD.			
.x±0.25	.x°± 2°	SIZE		SHEET	1 OF 4	APPROVED					
.xx±0.15	.xx°± 1°	A4									

RoHS Compliant HF

REV.	ECN.NO.	MODIFY.CONTENT
A		NEW
B	N23060601	CHANGE LATCH AND FIXD

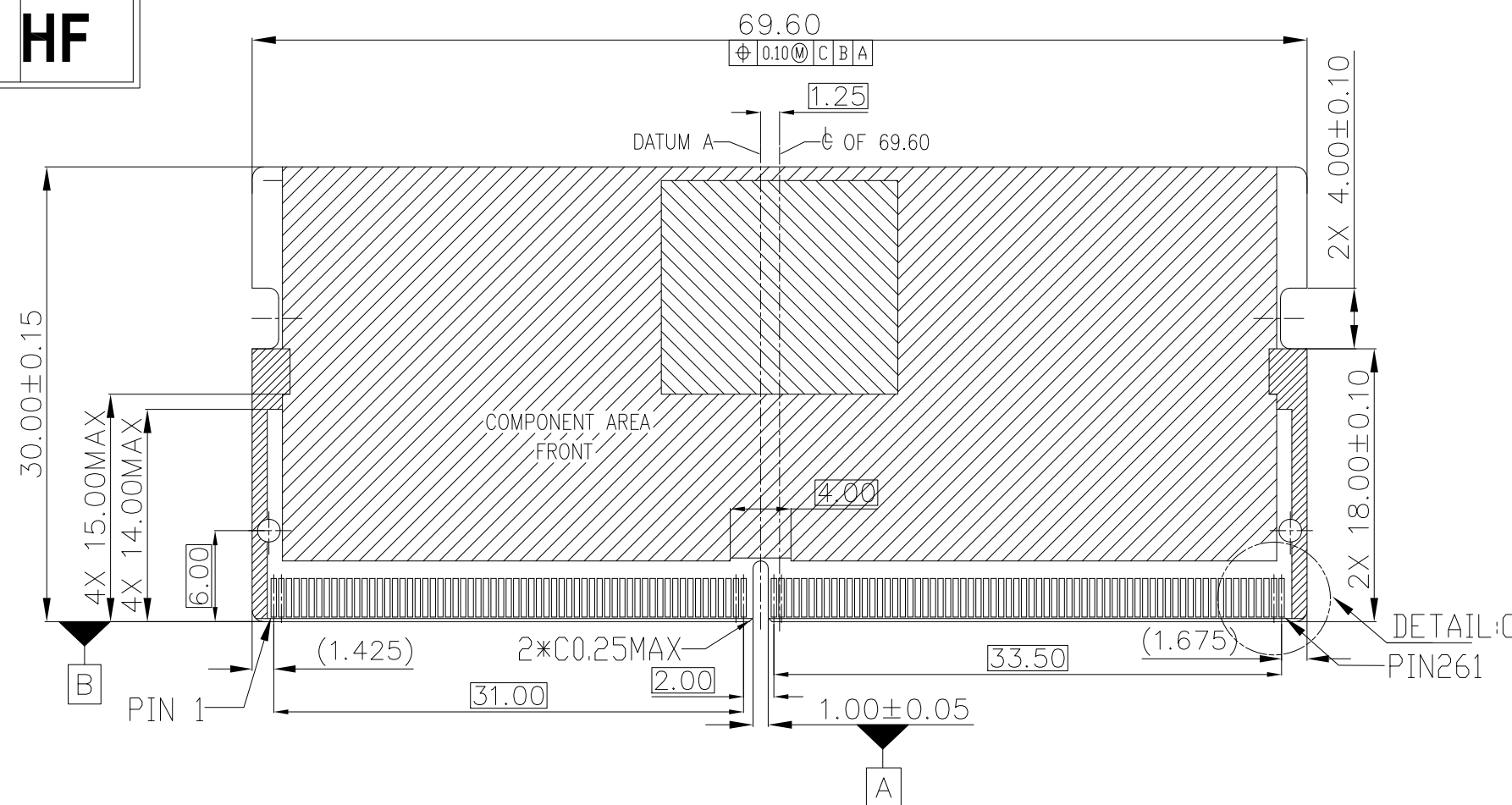

NOTES:
 1. DIMENSIONING AND TOLERANCING PER ASME Y14.5-2009.
 2. TOLERANCES ON ALL DIMENSIONS 0.15 UNLESS OTHERWISE SPECIFIED.
 3. ALL DIMENSIONS ARE MM.
 4. RECOMMENDED PLATING FOR CONTACT PADS ARE:
 1) VARIATION xxAx: GOLD PLATING 0.76 MICROMETERS MINIMUM OVER 2.00 MICROMETERS MINIMUM NICKEL.
 2) VARIATION xxBx: GOLD PLATING 0.05 MICROMETERS MINIMUM OVER 0.25 MICROMETERS MINIMUM PALLADIUM OVER 2.00 MICROMETERS MINIMUM NICKEL.
 3) VARIATION xxCx: GOLD PLATING 0.05 MICROMETERS MINIMUM OVER 2.00 MICROMETERS MINIMUM NICKEL.
 MODULE PLATING RECOMMENDATIONS TESTED PER INDUSTRY STANDARD EIA 364-1000. RELIABILITY TESTING REQUIRES TEST MODULE, CONNECTOR, AND IDENTIFICATION OF TEST CONDITIONS.

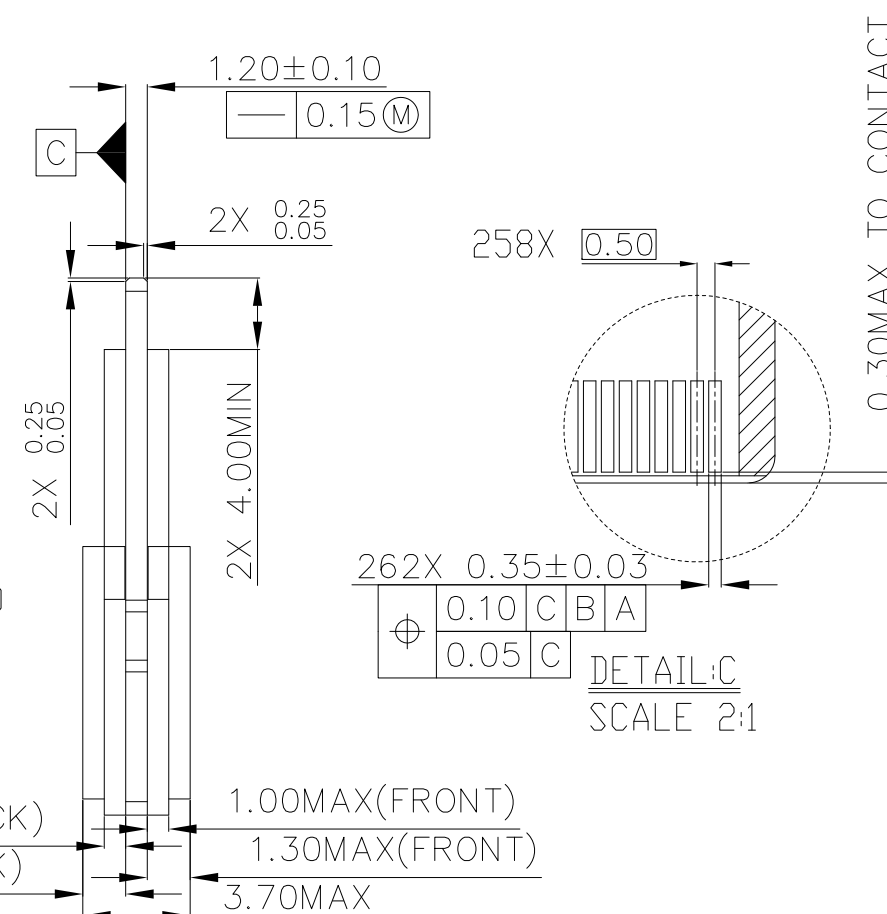
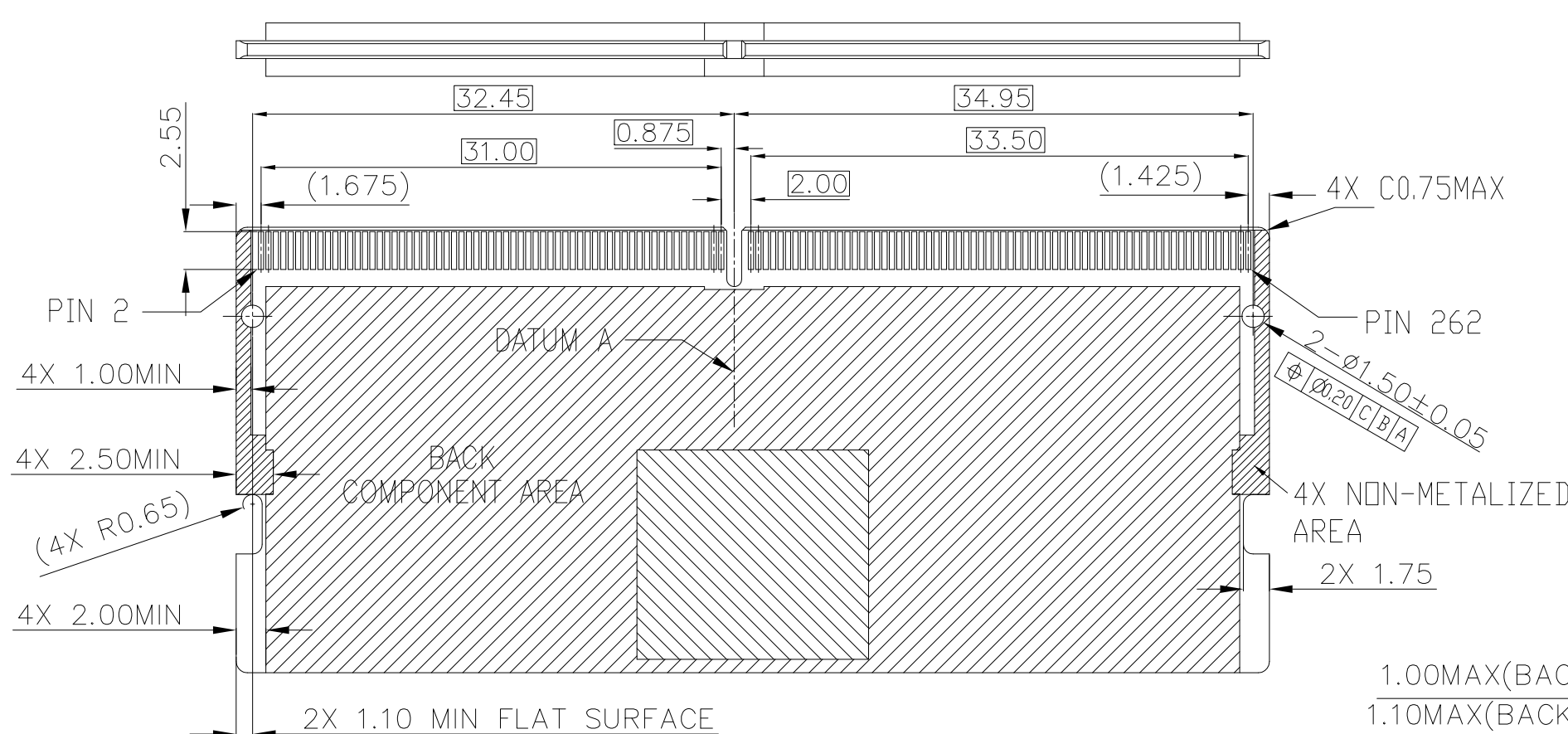

GENERAL TOLERANCE	TOLERANCE	DWG.NO.	DDR001-S5401-08	PART.NO.	DDR001-S5401-**	DRAWN	DU 2023-06-06	UNIT	mm	SCALE	NO SCALE
x.±0.50	x.°± 5°	REV.	B	TITLE	DDR5 SO DIMM 262Pin(RVS) H4.0	CHECKED		 东莞市欧联电子科技有限公司 DONGGUAN OLN ELECTRONICS TECHNOLOGY CO., LTD.			
.x±0.25	.x°± 2°	SIZE		SHEET	2 OF 4	APPROVED					
.xx±0.15	.xx°± 1°	A4									

RoHS Compliant HF

REV.	ECN.NO.	MODIFY.CONTENT
A		NEW
B	N23060601	CHANGE LATCH AND FIXD

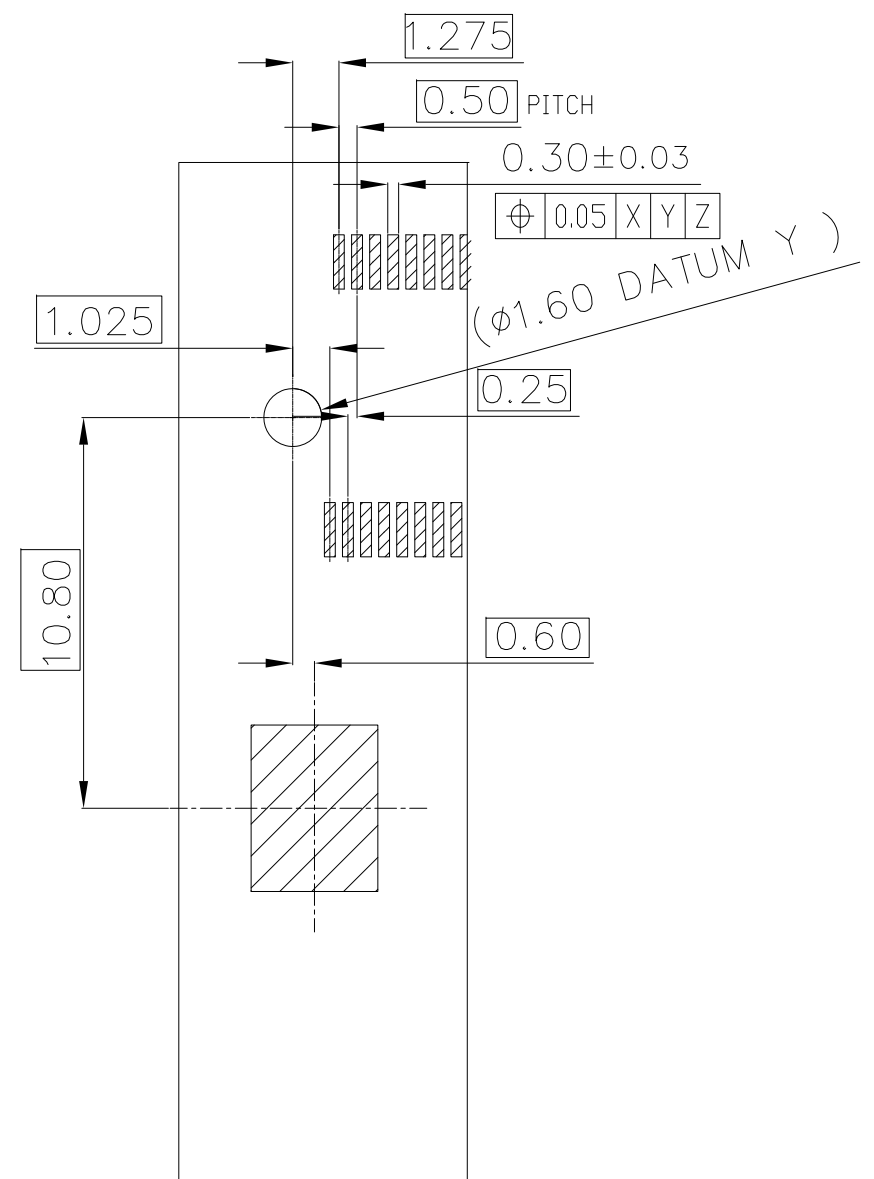
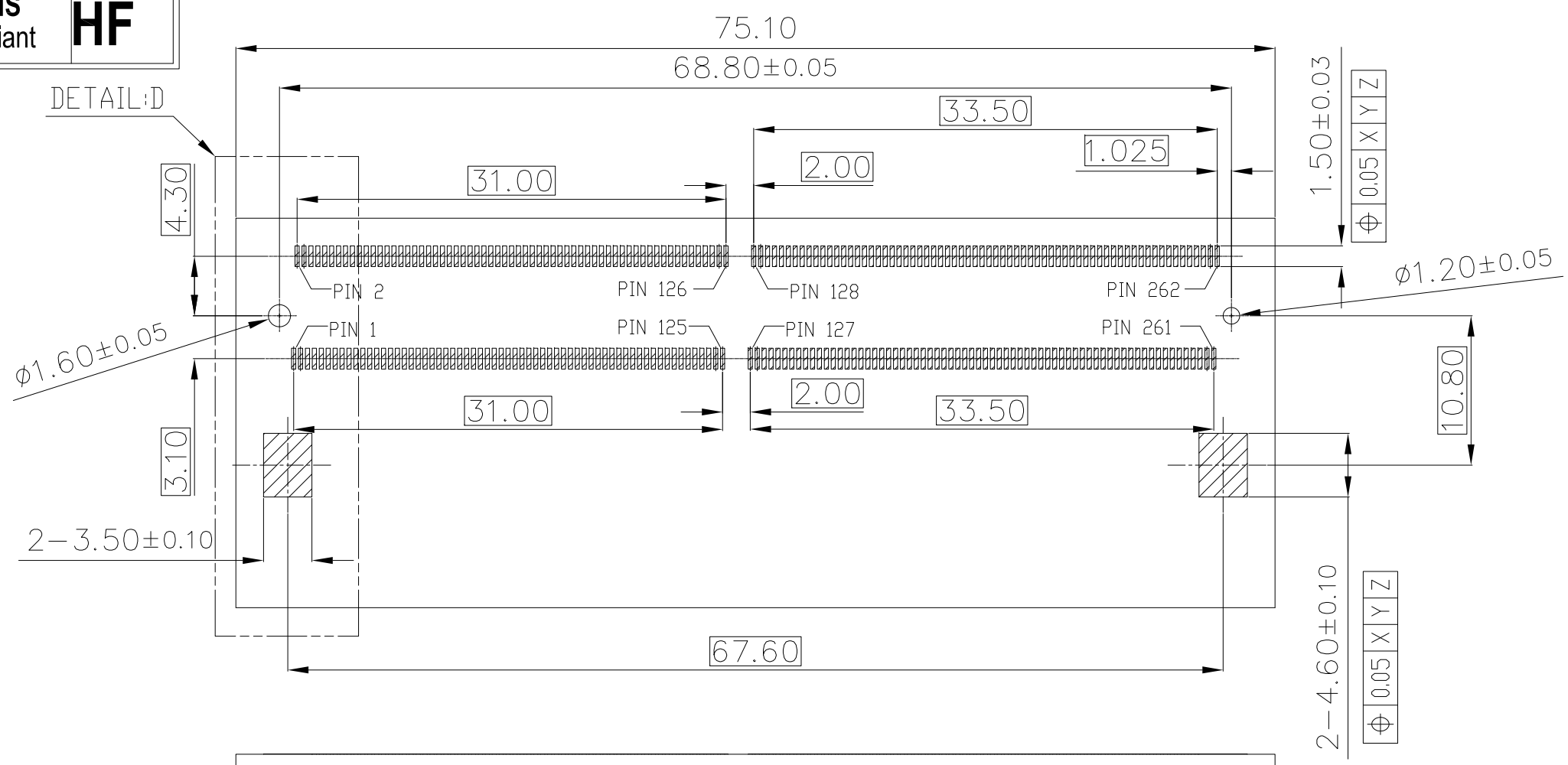

DETAIL:D
SCALE 2:1

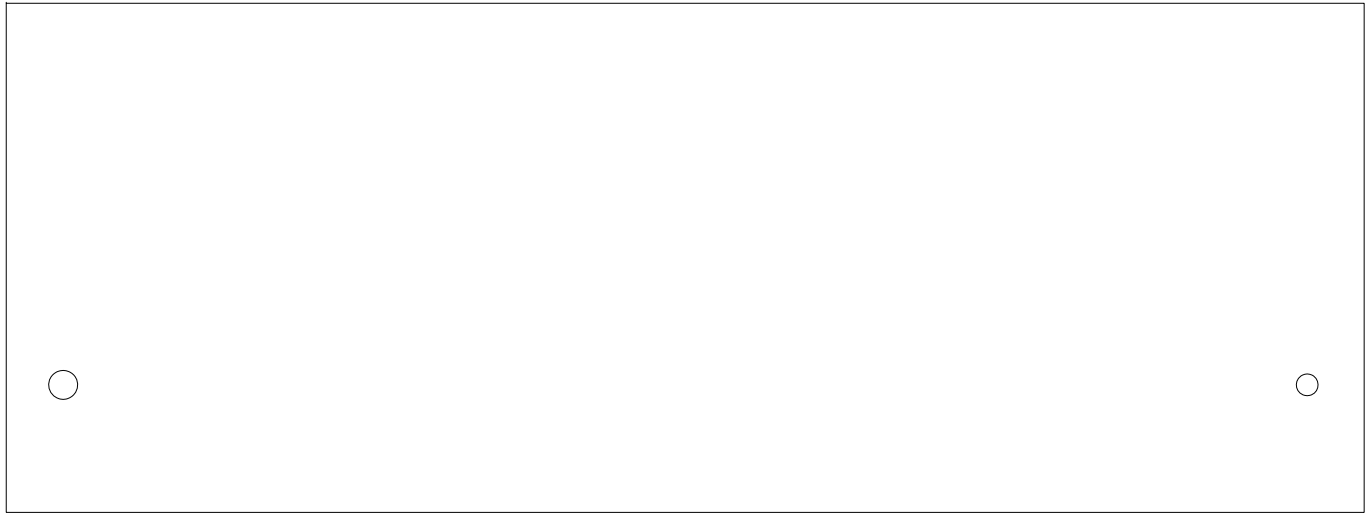

RECOMMEND PCB LAYOUT

THE TOLERANCE UNLESS SPECIFIED IS ±0.05 MM

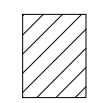
 Solder pad area

GENERAL TOLERANCE	DWG.NO.	DDR001-S5401-08	PART.NO.	DDR001-S5401-**	DRAWN	DU 2023-06-06
x.±0.50	REV.	B	TITLE	DDR5 SO DIMM 262Pin(RVS) H4.0	CHECKED	
.x±0.25	SIZE	A4	SHEET	3 OF 4	APPROVED	
.xx±0.15						

OLN[®] 东莞市欧联电子科技有限公司
DONGGUAN OLN ELECTRONICS TECHNOLOGY CO., LTD.

RoHS Compliant HF

REV.	ECN.NO.	MODIFY.CONTENT
A		NEW
B	N23060601	CHANGE LATCH AND FIXD

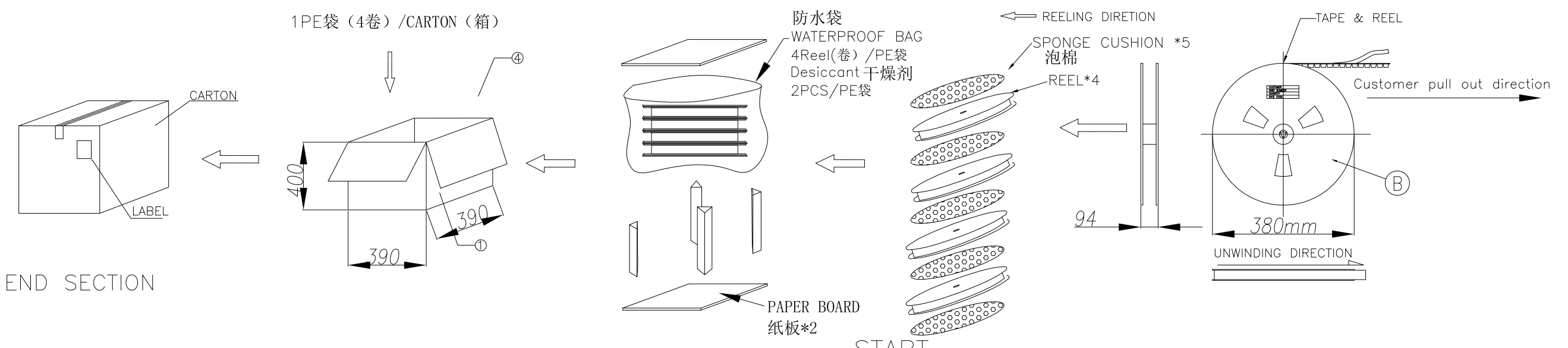
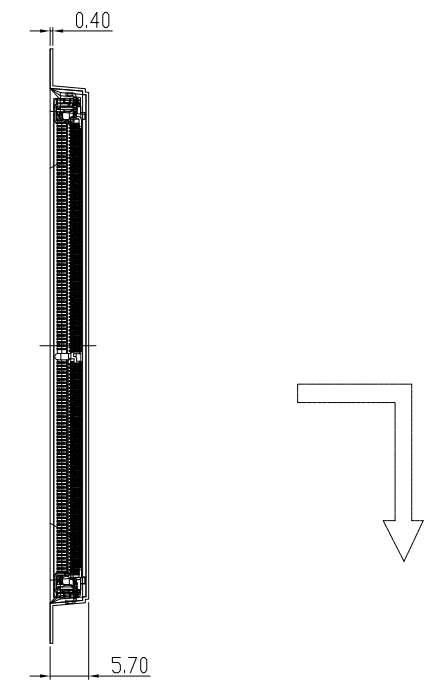
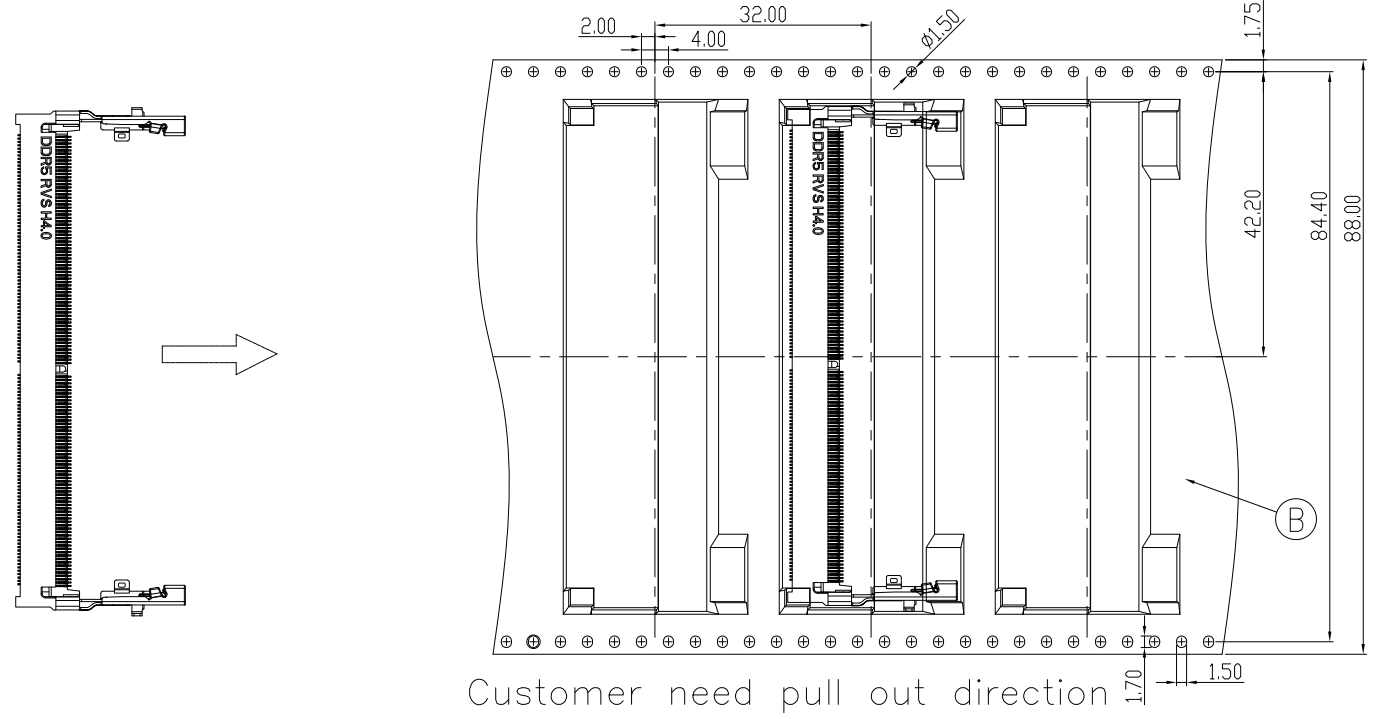

END SECTION

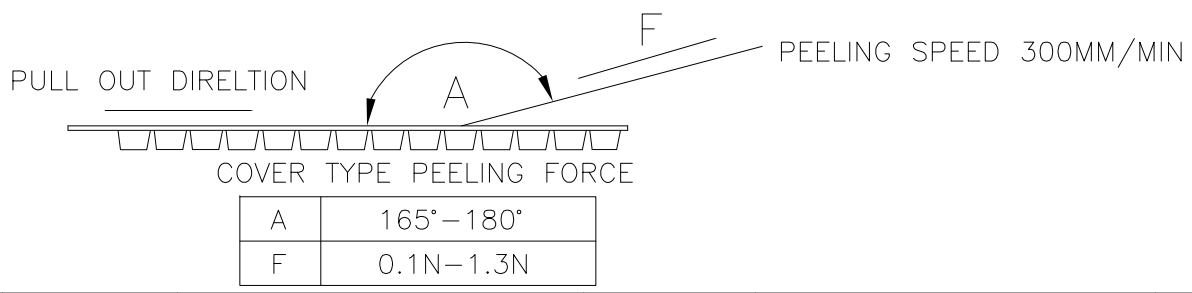
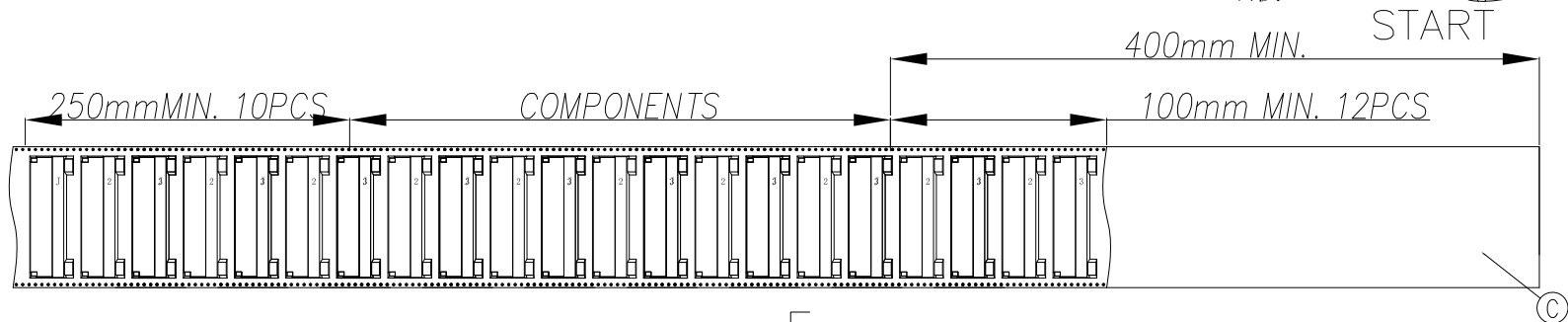

NOTES:

- Quantity:
500PCS/Reel
4 Reel/Carton: 2000 PCS/Carton
- Each plate needs vacuum packaging, and 2PCS desiccant is placed in the packaging bag

⑤	WATERPROOF BAG	1	
④	SUPPORT BRACE	4	
③	REEL ASS'Y	4	
②	CARRIER TAPE	4	
①	CARTON	1	
ITEM	MATERIAL	Q'TY	NOTE

GENERAL TOLERANCE	DWG.NO.	PART.NO.	DRAWN	UNIT
x.±0.50	DDR001-S5401-08	DDR001-S5401-**	DU 2023-06-06	mm
x.°± 5°	REV.	TITLE	CHECKED	SCALE
.x±0.25	B	DDR5 SO DIMM 262Pin(RVS) H4.0		NO SCALE
.x°± 2°	SIZE	SHEET	APPROVED	
.xx±0.15	A4	4 OF 4		

OLN® 东莞市欧联电子科技有限公司
DONGGUAN OLN ELECTRONICS TECHNOLOGY CO., LTD.